

CM 90S4

Gru idraulica a montaggio rapido

Hydraulic crane with quick assembling
Grue hydraulique à montage rapide
Hydraulischer Schnellmontagekran
Grúa hidráulica de montaje rápido

serie performance

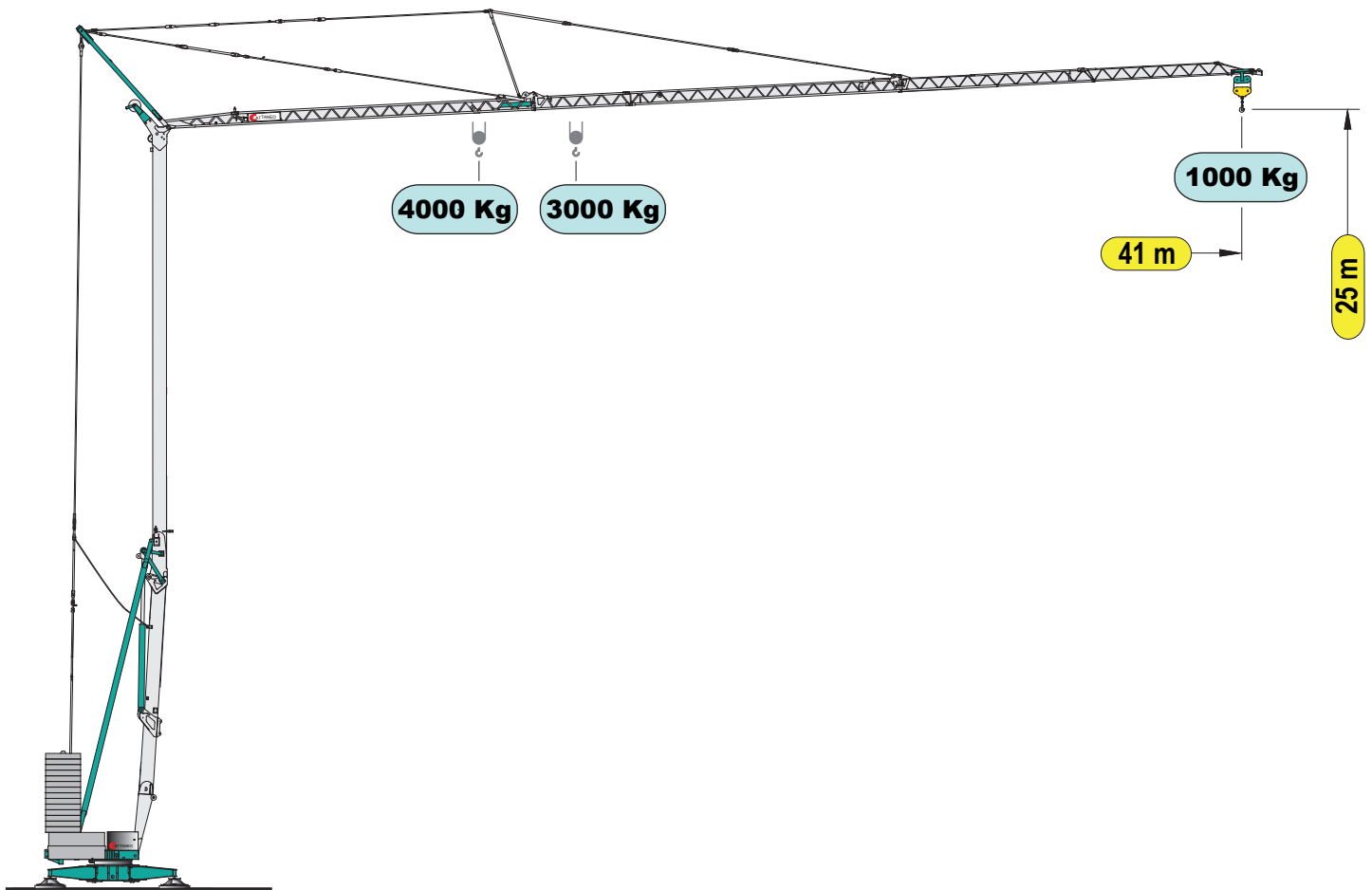

CATTANEO



EN 14439 C25

DIN 15018-H1/B3

CM 90S4

 Nessun componente elettrico sul braccio e sulle parti alte della gru
No electrical component on the jib and the top of the crane

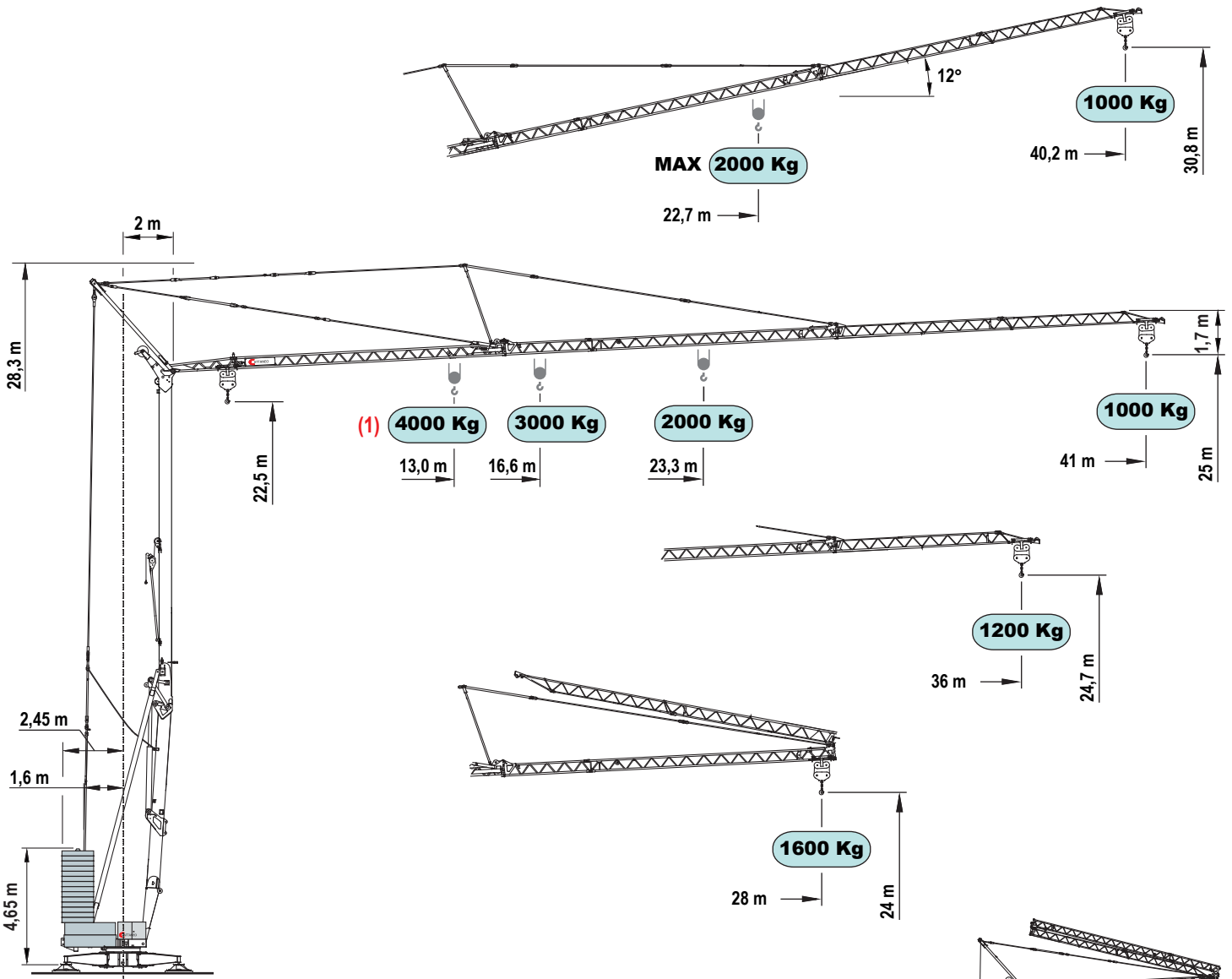

Max. kg 3000 - 4000

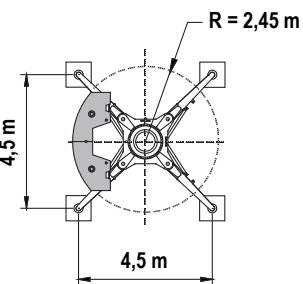

	kg	4000	3000	2500	2000	1900	1800	1700	1600	1500	1400	1300	1200	1100	1000
Curve di carico	kg	4000	3000	2500	2000	1900	1800	1700	1600	1500	1400	1300	1200	1100	1000
Load diagrams	m	13.0	16.6	19.3	23.3	24.2	25.3	26.5	27.9	29.4	31.1	33.1	35.5	37.8	41.0
Courbes de charge	m	13.1	16.9	19.6	23.6	24.6	25.8	27.0	28.4	30.0	31.7	33.7	36.0		
Lastkurven	m	13.0	16.6	19.4	23.3	24.3	25.4	26.6	28.0						
Curvas de cargas	m	13.0	16.6	19.4	23.3	24.3	25.4	26.6	28.0	28.8	30.5	32.4	34.6	37.0	40.2

Prestazioni - Performances - Prestations - Leistungen - Prestaciones

	 kW	 400V - 50Hz				16 kW	
						(1) 21 kW	
	kW/g/min		1°	2°	3°	4°	
			m/min	4	20	35	50
	inverter	11/1400		kg	3000	3000	1500
	(1) 18,5/1400		kg	4000	4000	2000	1500
	inverter	3/1400	m/min				10 - 25 - 50
	inverter	3,7/900	g/min				0,2 - 0,5 - 0,9

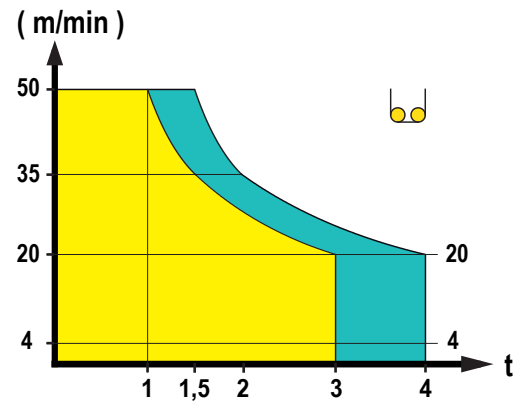

(1) Optional

Montaggio - Erection - Montage - Montage - Montaje

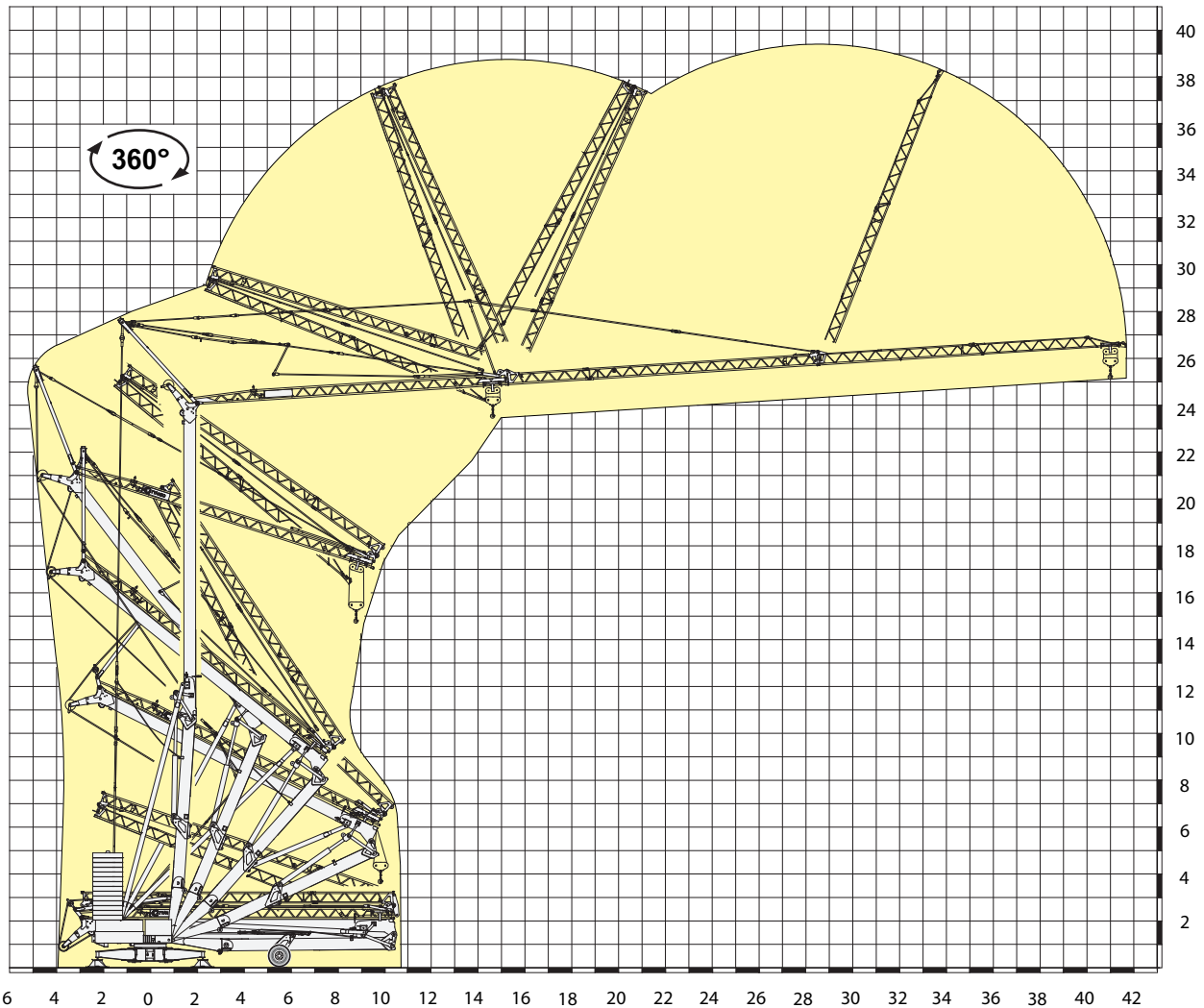

Contrappeso in lastre di cemento armato - Ferro-concrete ballast slabs
 Contrepoids en plaques de béton armé - Gegengewicht aus Betonplatten - Lastre en hormigón armado

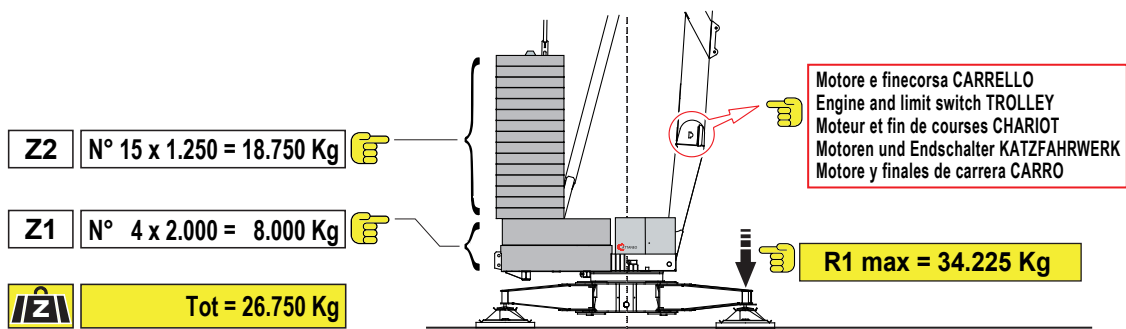

Trasporto - Transport - Transport - Transport - Transporte

19.350 kg Trasporto in sagoma su autoarticolato
 Transport in loading gauge on articulated lorry

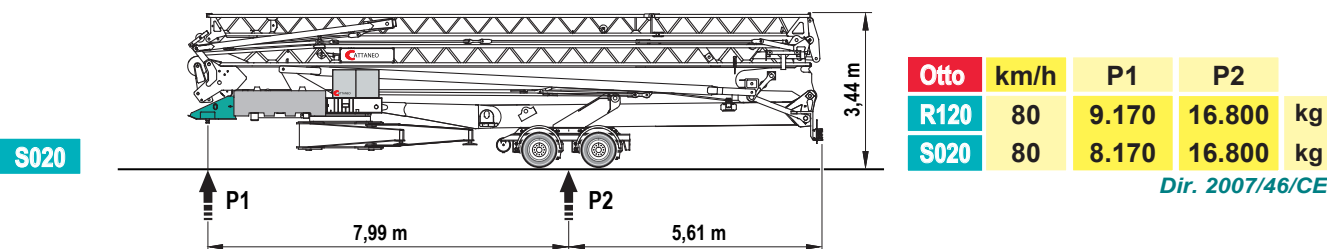
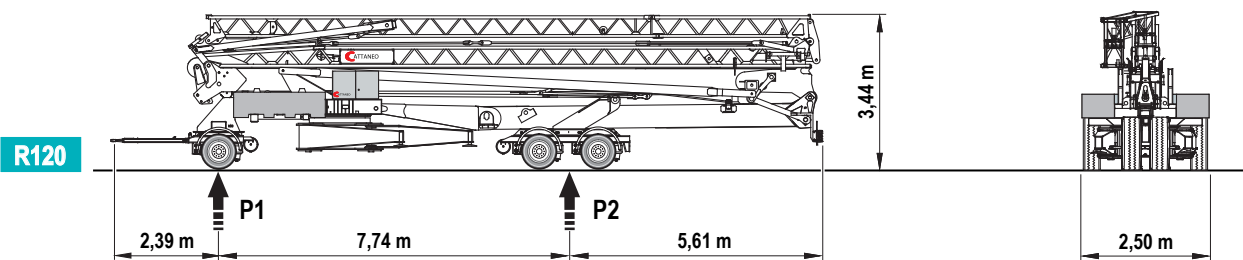
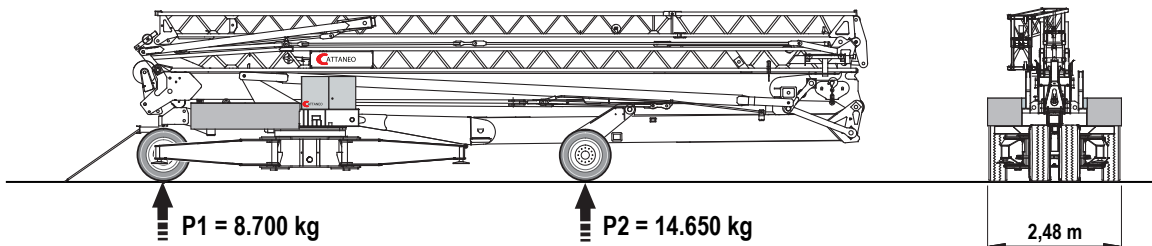
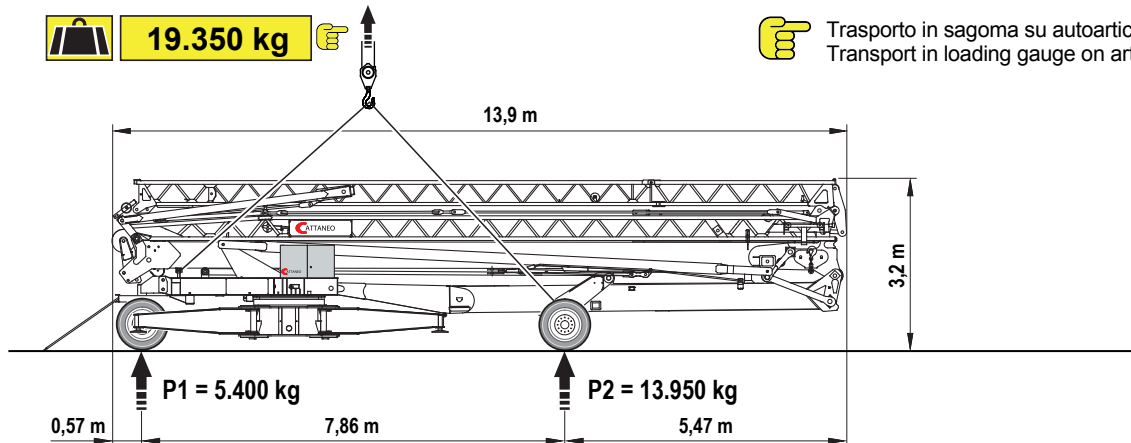

MH KRANER ApS

Jeppe Åkjærvej 30
 7500 Holstebro Mobil: 20833253
 Mail: Micaelhornstrup@hotmail.com